

## POWER INFORMATION

Input Voltage: 100-240 V AC  
Input Frequency: 50/60 Hz  
Amperage: 0.16-0.06 A  
Electric Consumption: 16 W  
Plug: Country-specific

## SIZING INFORMATION

-specified by volume or odor sources-  
AC-05: small, single closet  
AC-10: small to medium, ≤3 odor sources  
AC-20: medium, ≤6 odor sources  
AC-30: large, >6 odor sources  
-high trafficked areas may require a larger model-  
-large areas may require multiple units-

## FEATURES

Wall Plug or Mains Installation  
13 foot Power Cord (4 meters)  
Ceiling or Wall Mount Kit  
Space Saving Design

## APPLICATIONS

Animal Odor Removal  
Care Homes/Nursing Homes  
Food Storage  
Garbage/Rubbish Collection  
Gymnasiums  
Odor Abatement  
Restrooms/Washrooms  
Smoke Removal

## WARRANTY

Warranty valid in United States and Canada.  
Contact factory for warranty in other countries.  
One year Parts and Labor on entire unit.

## Product Certifications:



## BioZone AC System



**AC-30**  
Top View Shown



**AC-30**  
Side View Shown



**AC-30**  
End View Shown

- Eliminate odors, smoke, and chemicals
- Reduce bacteria, viruses, mold, and other micro-contaminants
- Improve the hygiene in the air and on surfaces
- Certified to be safe, proven to be effective
- Designed specifically for Restrooms/Washrooms – and more
- Portable or fixed installations
- Completely automated and chemical-free
- Maintenance free – requires simple annual UV lamp replacement(s)

© BioZone Scientific International, Inc.

7616 Southland Blvd  
Suite 114  
Orlando, FL 32809  
USA



**BioZone AC 05, 10, 20, 30**  
**Product Family: BioZone AC**  
**Model: AC-05, AC-10, AC-20, AC-30**  
**Description: Air and Surface Purifier**



**REORDER INFORMATION**  
**Replacement UV Lamps**

AC-05: 10-08010  
 AC-10: 10-08025  
 AC-20: 10-08050  
 AC-30: 10-08100

**SPECIFICATIONS**

Length: 16.2"  
 Width: 5.2"  
 Height: 3.65"  
 Weight: 2.5 lbs  
 Power Cord Length: 13'

**CONTENTS**

BioZone  
 UV Lamp (pre-installed)  
 Owner's Manual and Installation Guide  
 Lock Key  
 Wall Anchor (optional)  
 Mounting Screws (optional)

**Validation Studies**

BioZone Technology is shown to reduce:  
 >99.999% of surface E. coli<sup>1,2</sup>  
 >99.999% of surface Listeria<sup>2</sup>  
 100% of surface Salmonella<sup>2</sup>  
 98.24% of airborne bacteria<sup>3</sup>  
 100% of airborne H<sub>2</sub>S<sup>4</sup>  
 >99.999 of Avian Influenza Virus (H5N2)<sup>5</sup>  
 >99.999 of Parainfluenza Virus (hPIV-3)<sup>5</sup>

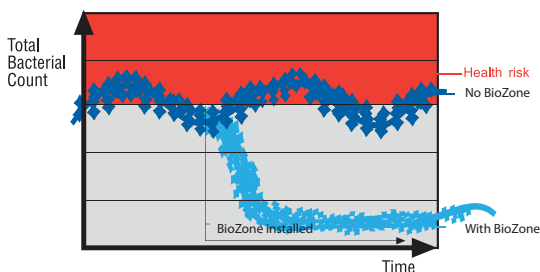

1 Test performed by Pennsylvania State University  
 2 Test performed by Tri-Tech Analytical Laboratories  
 3 Test performed by LAWN Environmental Ltd  
 4 Test performed by SMQ Academy  
 5 Test performed by CNRS

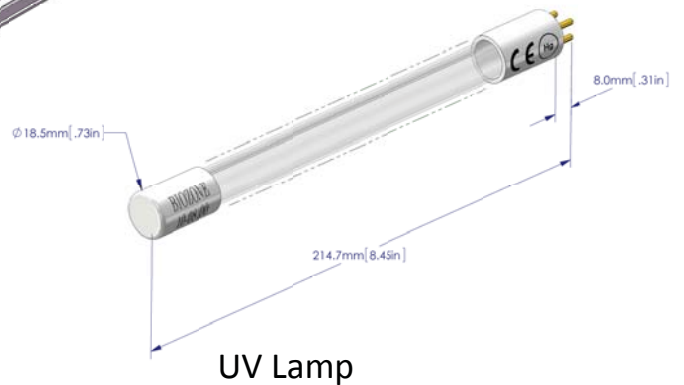
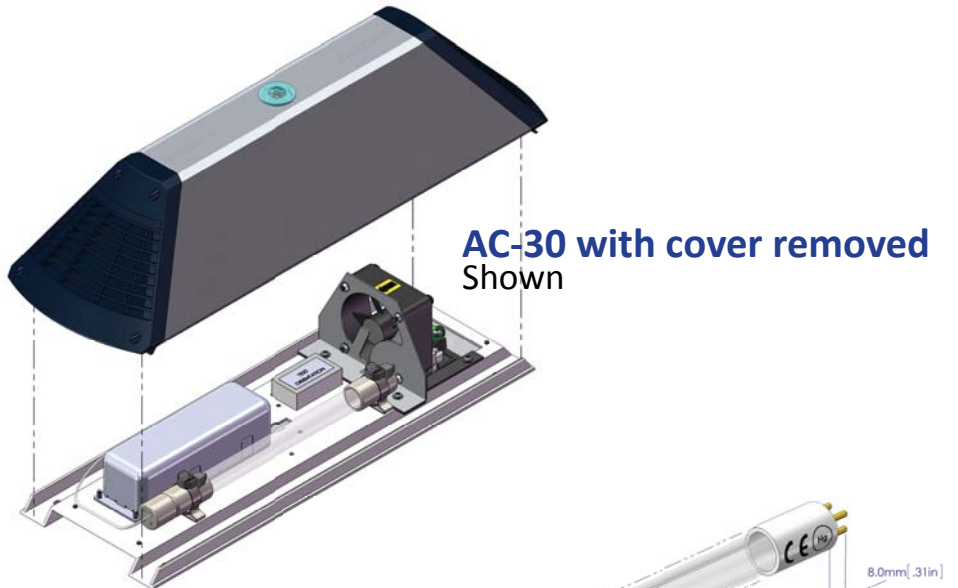

© BioZone Scientific International, Inc.

7616 Southland Blvd  
 Suite 114  
 Orlando, FL 32809  
 USA

